



# 精密液壓分度盤(三片式離合齒)

## HYDRAULIC COUPLING GEAR INDEX TABLE







### 特點

1. 液壓驅動排齒與傳動齒組搭配可調式緩衝裝置，內建三片式離合齒定位與鎖緊裝置。
2. 其工作站調整簡單，標準分度4、6、8、12、24，特殊分割可另行製造。
3. 液壓鎖緊系統，油壓使用壓力為35kg/cm<sup>2</sup> 水平放置使用，盤面可加工。

### 表示方法

<b>RCT</b>	<b>340</b>	<b>x</b>	<b>6</b>
系列	圓盤大小		等份
	Ø200		4等份
	Ø340		6等份
	Ø470		8等份
	Ø600		12等份
			24等份

### 規格

系 列	RCT-200	RCT-340	RCT-470	RCT-600	
使用流體	液壓				
操作壓力	3.5MPa (35kgf/cm <sup>2</sup> )				
迴轉方向	順時針 (CW)/ 逆時針 (CCW)				
產品重量	50 kg	115 kg	270 kg	480 kg	
產品總高(水平放置)	175 mm	210 mm	240mm	260 mm	
面板直徑	Ø200 mm	Ø340 mm	Ø470 mm	Ø600 mm	
面板主軸中心孔	Ø30 mmH6	Ø65 mmH6	Ø90 mmH6	Ø110 mmH6	
面板主軸中心孔深度	30 mm	11 mm			
面板主軸中心貫穿孔	Ø27 mm	Ø30.5 mm	Ø41 mm	Ø53 mm	
割出等份	4、6、8、12、24				
重現精度	±1"				
割出精度(累積值) (sec)	±4"				
旋轉扭力	25 kg-m	57 kg-m	86 kg-m	144 kg-m	
容許瞬間慣性WR <sup>2</sup>	7 kg-m <sup>2</sup>	21.25 kg-m <sup>2</sup>	45 kg-m <sup>2</sup>	125 kg-m <sup>2</sup>	
旋轉90°的時間	1.7s	2.3s	3.4s	5.4s	
鎖緊 扭力	F  (kgf) (N)	1260 12340	1560 15200	3970 38500	6448 63000
	F x L  (kg-m) (N-m)	108 1060	332 3250	1428 13990	1980 19400
	F x H  (kg-m) (N-m)	55 541	145 1423	550 5390	840 8232
最大 載重	0°  (kg)	120 kg	500 kg	700 kg	1250 kg

★旋轉90°的時間(鬆開、旋轉、鎖緊)，係指使用壓力35kg/cm<sup>2</sup>，2HP，30L/min 等有條件的預測值

外形尺寸表

RCT 200

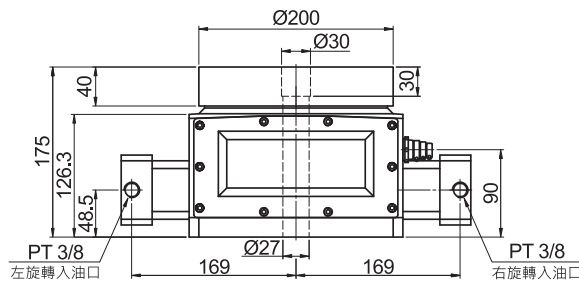
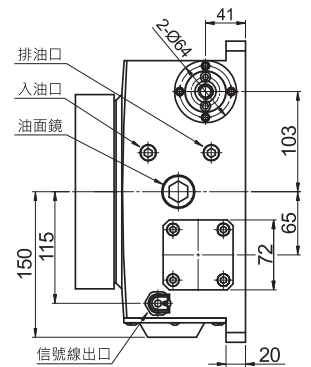
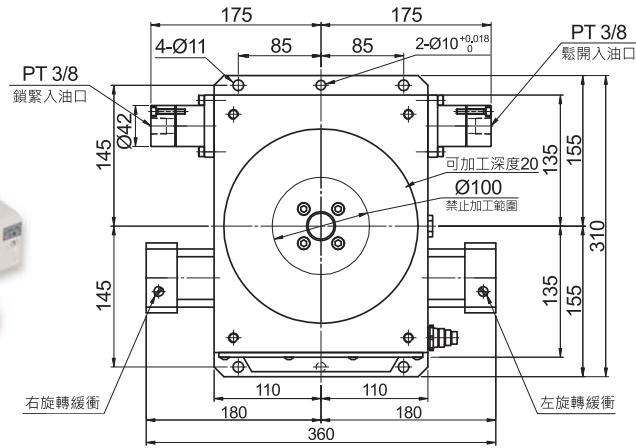

RCT 340

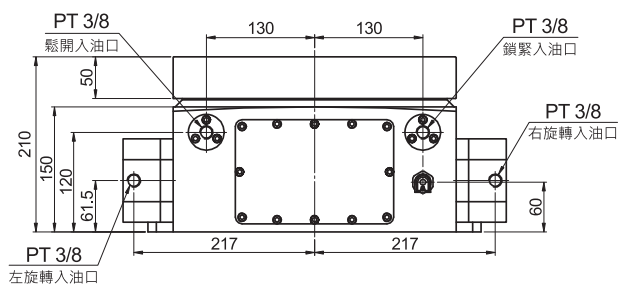
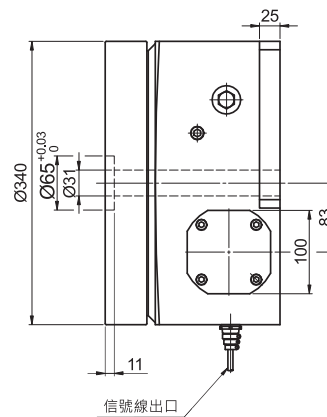
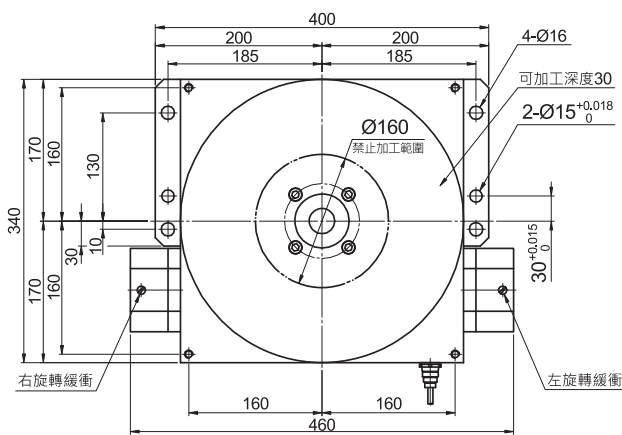



# 精密液壓分度盤(三片式離合齒)

## HYDRAULIC COUPLING GEAR INDEX TABLE

### 外形尺寸表

#### ● RCT 470

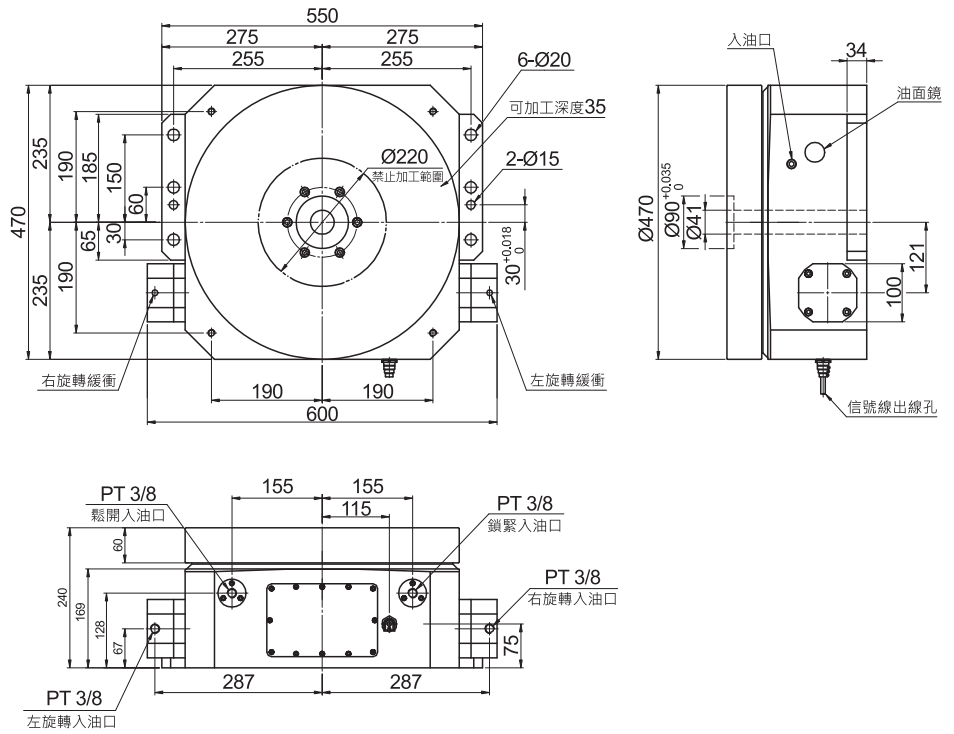

#### ● RCT 600

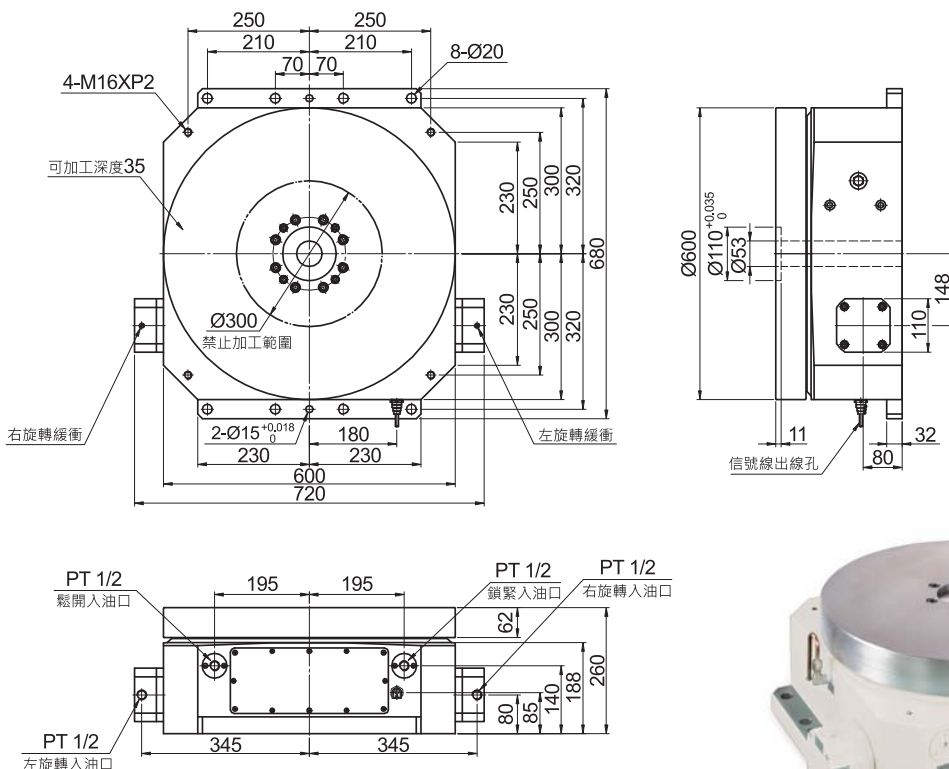

# RCT 系列

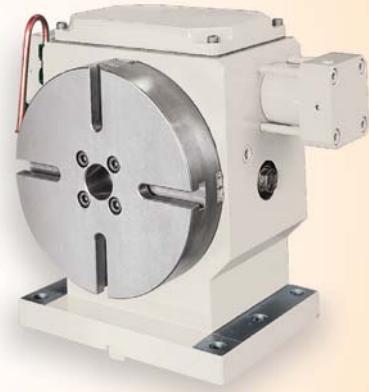





## 特點

1. 液壓驅動排齒與傳動齒組搭配可調式緩衝裝置，內建三片式離合齒定位與鎖緊裝置。
2. 其工作站調整簡單，標準分度4、6、8、12、24，特殊分割可另行製造。
3. 液壓鎖緊系統，油壓使用壓力為35kg/cm<sup>2</sup>立式垂直放置使用，可搭配圓盤式剎車尾座結合治具使用。

## 表示方法

<b>RCT</b>	<b>V</b>	<b>200</b> X	<b>6</b>
系列	型式	圓盤大小	等份
	立式垂直	Ø200 Ø250 Ø320	4等份 6等份 8等份 12等份 24等份

## 規格

系 列	RCT-V200	RCT-V250	RCT-V320	
使用流體	液壓			
操作壓力	3.5MPa (35kgf/cm <sup>2</sup> )			
迴轉方向	順時針 (CW)/ 逆時針 (CCW)			
產品重量	50 kg	110 kg	170 kg	
面板直徑	Ø200 mm	Ø250 mm	Ø320 mm	
產品總高(水平放置)	285 mm	362 mm	395 mm	
面板主軸中心孔	Ø30 mmH6	Ø55 mmH6	Ø65 mmH6	
面板主軸中心孔深度	35 mm	12 mm	31 mm	
面板主軸中心穿透孔	Ø27 mm	Ø30 mm	Ø41 mm	
割出等份	4、6、8、12、24			
重現精度	±2"			
割出精度(累積值) (sec)	±4"			
旋轉扭力	25 kg-m	37 kg-m	60 kg-m	
容許瞬間慣性WR <sup>2</sup>	7 kg-m <sup>2</sup>	10 kg-m <sup>2</sup>	21.25 kg-m <sup>2</sup>	
旋轉90°的時間	1.7s	2.0s	2.3s	
鎖緊 扭力	F  (kgf) (N)	1260 12340	1410 13818	1560 15200
	F x L  (kg-m) (N-m)	108 1060	208 3041	332 3250
	F x L  (kg-m) (N-m)	55 541	122 1200	145 1423
最大 載重	0°  (kg)	95 kg	130 kg	200 kg

\* 旋轉90°的時間(鬆開、旋轉、鎖緊)，係指使用壓力35kg/cm<sup>2</sup>, 2HP, 30L/min 等有條件的預測值



# 精密液壓分度盤 (三片式離合齒)

## HYDRAULIC COUPLING GEAR INDEX TABLE

### 外形尺寸表

#### ● RCTV 200

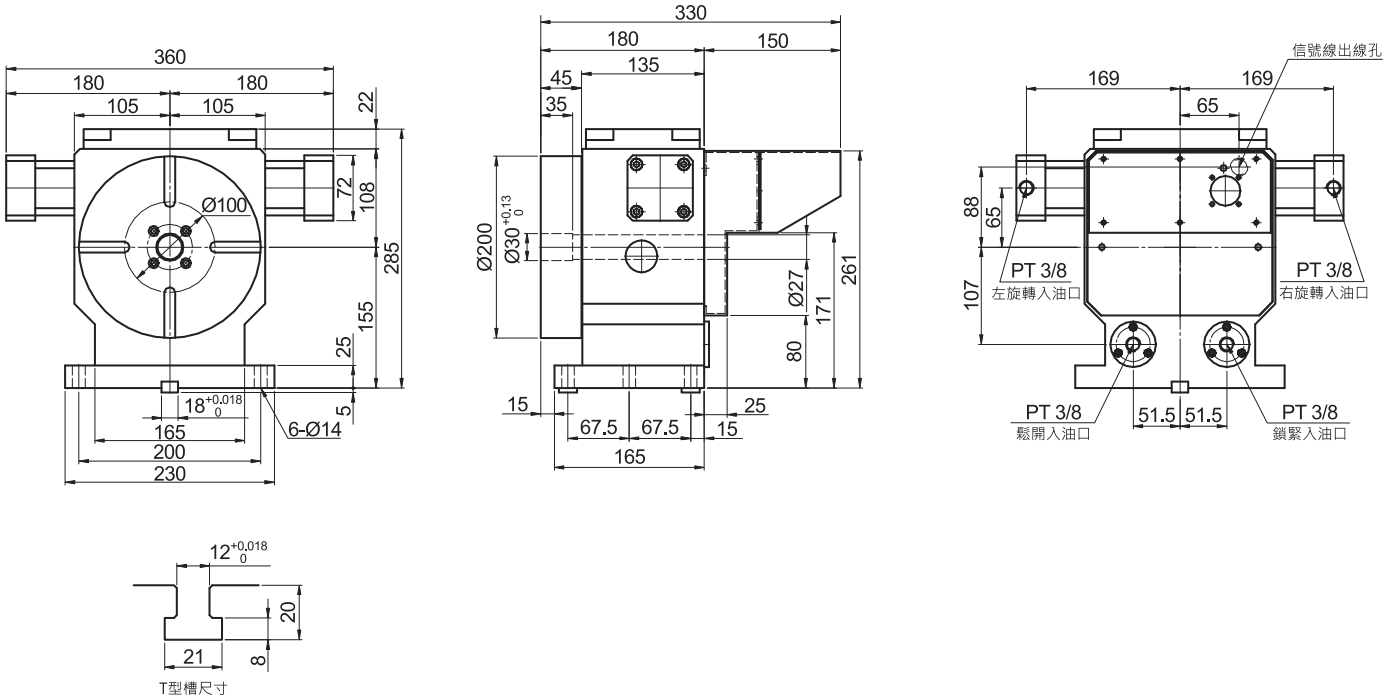

#### ● RCTV 250

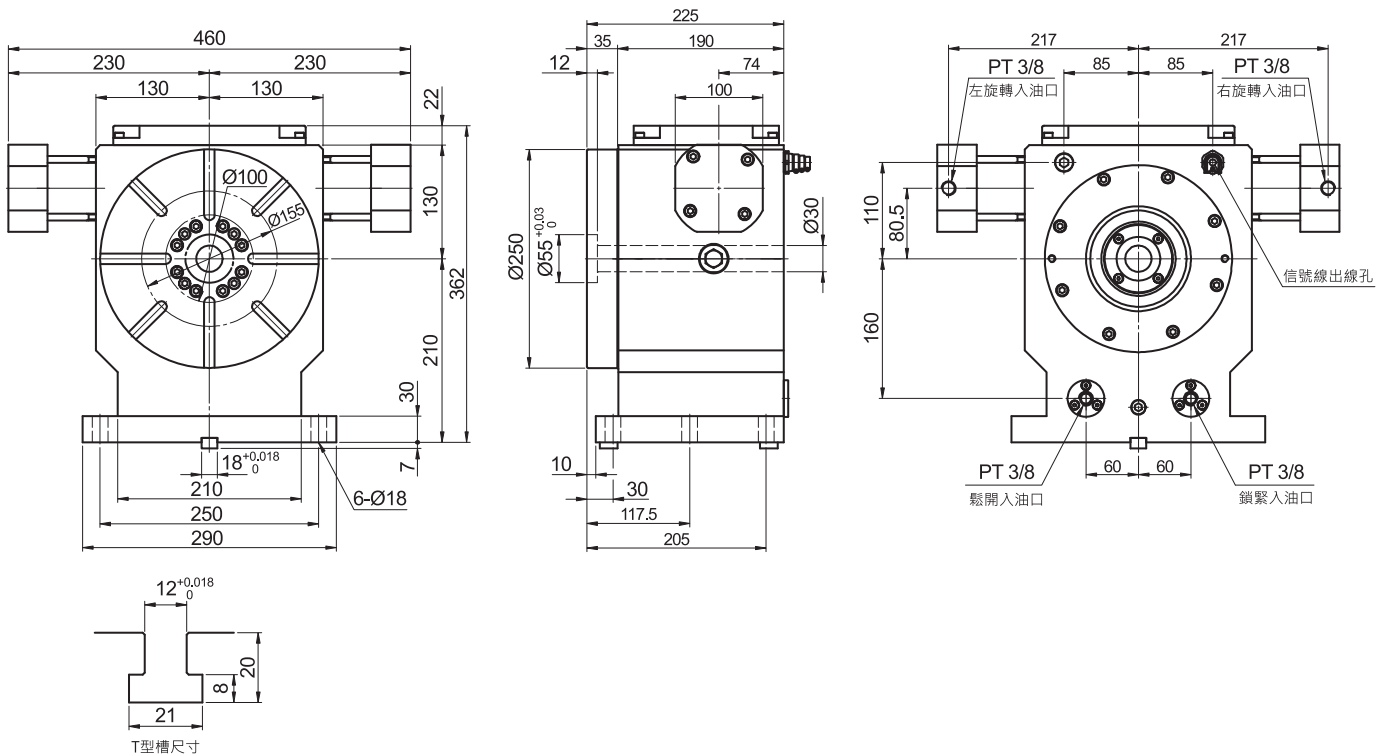

● RCTV 320

